



**GREENOLIVE<sup>®</sup>**  
*made from plants*

**MORE CHOICES**  
**BETTER PRICES**

[www.ecogreenolive.com](http://www.ecogreenolive.com) | [www.greenolives.com.cn](http://www.greenolives.com.cn)



# SAFE, HEALTHY AND NON-TOXIC ECO-FRIENDLY PRODUCTS



LONGYAN GREEN OLIVE CO.,LTD



# ABOUT US

Welcome to GREENOLIVE, your gateway to a world of sustainable innovation. We are a passionate and dedicated team committed to revolutionizing the way we interact with our environment through the creation of premium-quality, eco-friendly products made from bagasse.

## Our Story:

Driven by a shared vision of a cleaner, greener future, GREENOLIVE was founded with the mission to combat plastic pollution and promote conscious consumption. Our journey began with a simple yet powerful idea: to harness the untapped potential of bagasse, a natural byproduct of sugarcane, and transform it into elegant and functional alternatives to conventional plastic products.

## Our Commitment:

**Environmental Stewardship:** Our commitment to the environment goes beyond lip service. Every product that bears the GREENOLIVE signature is a testament to our dedication to minimizing waste, reducing our carbon footprint, and contributing positively to the planet.



## Our Mission :

our mission is clear and unwavering: to lead the way in revolutionizing the global packaging landscape by crafting high-quality, eco-friendly products from bagasse, while fostering sustainability, innovation, and positive environmental change.



## Our Vision :

our vision is to pave the way for a global transformation towards sustainable living by reimagining the potential of bagasse, championing environmental harmony, and inspiring a new era of responsible consumption.

# WHY CHOOSE US



Food Grade



Microwave Safe  
Freezer Safe



Waterproof  
Leak Proof



Environmental  
Friendly

400+

covering an area of  
26400 m<sup>2</sup>

120+

Employs more than  
120 workers

1500

Annual output value  
of 15 million US dollars

ISO9001

Factory has passed  
ISO9001 certification

## Our Competitive Advantage

The company is committed to building a most respected integrated famous supplier from raw material to final product entire industrial chain business system and serve all major fields in the world, by the advantages in cost, scientific formula, cutting edge automatic equipment and technique, as well as our R&D capabilities, strong marketing team and strict quality control. Our team uses modern scientific and advanced management concepts and methods to turn our production base into a modern exclusive factory.

## Development Plan

The organization is going to set up the 2nd, 3rd and 4th production bases which will be put into production from May of 2022 and 2025 as planned. The total expected output will achieve 105,000 tons per year with an expected total revenue of US\$2100 million after the 4 production bases put into operation.

The company looks to turn Longyan production base into a modern exclusive demonstration factory by adopting modern management concept, and build a couple of new factories in China and South Asian area to meet market needs.

# CHINA'S LARGEST CUP LID FACTORY

Where Innovation Meets Sustainability, Our state-of-the-art facility is a hub of creativity and conscious production, dedicated to crafting high-quality, eco-friendly products that leave a positive mark on the planet. Discover innovation on a grand scale at our state-of-the-art cup lid manufacturing facility. As the industry's frontrunner, we are committed to producing top-quality, sustainable cup lids that redefine convenience and environmental responsibility.



# PIONEERING SUSTAINABILITY THROUGH INNOVATION

## RESEARCH AND DEVELOPMENT (R&D) :

Welcome to the heart of innovation at GREENOLIVE. Our Bagasse Research and Development (R&D) division is a dynamic hub where creativity, science, and sustainability converge. With a passion for pushing boundaries, we are committed to harnessing the full potential of bagasse to create cutting-edge, eco-friendly products that leave a positive impact on our planet.

## MOLD DEVELOPMENT :

At GREENOLIVE, we are dedicated to pushing the boundaries of sustainable manufacturing. Our bagasse mold development process stands as a testament to our commitment to transforming agricultural waste into functional and eco-friendly products, while pioneering innovation that makes a positive impact on our planet.

## PRODUCT DEVELOPMENT :

At GREENOLIVE, Our dedicated team blends creativity, research, and cutting-edge technology to transform sustainable concepts into practical eco-friendly solutions. From concept to reality, we transition to prototyping. Utilizing advanced 3D modeling and rapid prototyping techniques, we give form to our ideas, meticulously crafting prototypes that undergo rigorous testing and refinement.

100% NATURAL | PLASTIC-FREE | COMPOSTABLE | BIODEGRADABLE | CERTIFIED PRODUCTS | SUSTAINABLE | DISPOSABLE



# R & D CAPABILITIES

Engineering Team with Expertise-Green Olive R&D team is lead by the Chief Engineering with over 10 years in molded pulp fiber industry with over 30 engineers

- Patents-Over 10 patents achievements since establishment, continuing increasing with 4 patents applications each month
- In-house Mold Building-For better quality control and swift turnaround of molding, Green Olive has built its own mold building house



PATENTS



To better serve the factory and quality control, we have an engineering team of 10 engineers for molding at Phase 1 plant. And 3 CNC machines has been in place, more machines will be introduced as demanded by the production center

Lead time: Test Mold 7days  
 Mass production mold: Semi-automatic mold 15-20days;  
 Automatic mold: 30-35days

# UNITING FOR A GREENER WORLD: OUR TEAMWORK

At GREENOLIVE, our diverse and dedicated team comes together with shared passion and purpose. Through collaboration and synergy, we turn ideas into reality, creating innovative solutions that make a positive impact. Join us on this journey of teamwork and transformation.



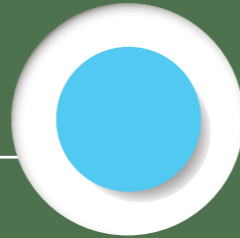

**BIODEGRADABLE CERTIFIED &  
QUALITY GUARANTEED**

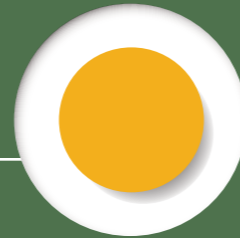

**STRONG R&D & TECHNICAL SUPPORT**



**FACTORY DIRECT WITH COMPETITIVE PRICE**



**AUTOMATIC PRODUCTION & FAST DELIVERY**

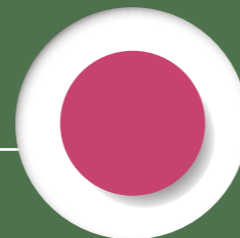

**ONE STOP &  
CUSTOMIZABLE SERVICE AVAILABLE**

# OUR CERTIFICATIONS

Green Olive has done a full set of certifications regarding the factory and products including ISO, BRC, BSCI, BPI, Industrial Compostable Certificates according to EN13432, ASTM D6400 and AS4736, FDA, LFGB and REACH, etc. We are proud to be rate Grade A by BRCGS this August and will continue to maintain and improve daily quality control practice to get a higher rating for the next renewal period.



RECYCLABLE



ISO9001  
ISO14001

ABA AS 4736

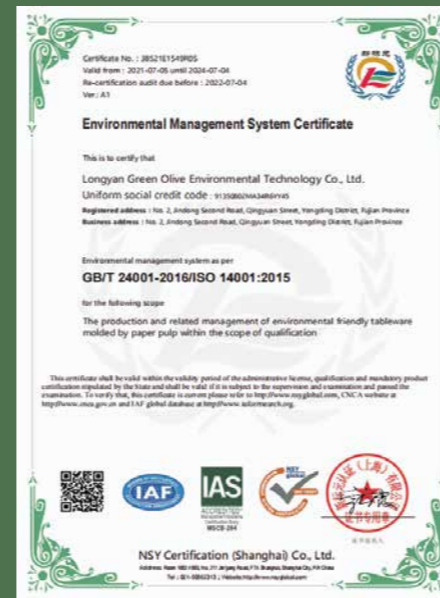

# VALUABLE TRUSTS



# PHASE I PLANT - LID WORKSHOP



# GREENOLIVE - PHASE I PLANT



**Longyan Green Olive Environmental Protection Technology Co., Ltd**

Head office: Room 906.Bldg.B.Business Center, Xinluo District, Longyan, Fujian 364000,China  
Factory Add: No. 2, Jindong 2nd Road, Fengcheng Street, Yongding South Industrial Park,  
Yongding District, Longyan, Fujian 364000,China

# PHASE II PLANT - LAYOUT & PLANNING



The total planning area of the second phase is **400** acre, about **270,000** square meters.

At present, the workshop that is normally put into production is No. 3 / No. 4 / No. 5

Workshop 1 / 2 will be completed By the end of **2024**, the number of tableware and cup lid machines will reach 150, and by the first half of 2024, it is planned to put into production 300 tableware and cup lid machines

# CUP LID



## GO-CR802

Size: 85\*20mm  
Thickness: 0.6mm  
N.W.: 4g±0.5g  
Color: White/Natural  
Packing: 50pcs/bag, 1000pcs/ctn  
Ctn. Size(mm):450\*360\*315  
CBM/Ctn: 0.051m<sup>3</sup>  
Fit 80mm diameter cups  
Usually for hot drinking

## GO-CR902

Size: 95\*20mm  
Thickness: 0.6mm  
N.W.:5g±0.5g  
Color: White/Natural  
Packing: 50pcs/bag, 1000pcs/ctn  
Ctn. Size(mm): 450\*360\*265  
CBM/Ctn: 0.0625m<sup>3</sup>  
Fit 90mm diameter cups  
Usually for hot drinking

## GO-CR807

Size: 84\*17.8mm  
Thickness: 0.6mm  
N.W.: 4g±0.5g  
Color: White/Natural  
Packing: 50pcs/bag, 1000pcs/ctn  
Ctn. Size(mm):450\*360\*310  
CBM/Ctn: 0.0502m<sup>3</sup>  
Fit 80mm diameter cups  
Usually for hot drinking

## GO-CR907

Size: 94.5\*17.8mm  
Thickness: 0.6mm  
N.W.:5g±0.5g  
Color: White/Natural  
Packing: 50pcs/bag, 1000pcs/ctn  
Ctn. Size(mm):502\*402\*310  
CBM/Ctn: 0.0626m<sup>3</sup>  
Fit 90mm diameter cups  
Usually for hot drinking

# CUP LID



**CO-CR62**

size:65\*15mm  
Thickness:0.6mm  
N.W:2.5g±0.5g  
Color: white/Natural  
Packing: 50pcs/bag, 2000pcs/ctn  
Ctn.Size(mm):540\*345\*230CBM/  
Ctn:0.0428m<sup>3</sup>  
Fit 62mm diameter cups  
Usually for hot drinking



**CO-CR908**

size:95\*18mm  
Thickness:0.6mm  
N.W:5g±0.5g  
Color: white/Natural  
Packing: 50pcs/bag, 1000pcs/ctn  
Ctn.Size(mm):500\*400\*310CBM/  
Ctn:0.062m<sup>3</sup>  
Fit 90mm diameter cups  
Usually for hot drinking



**GO-CR801**

Size: 85\*23.1mm  
Thickness: 0.6mm  
N.W.: 4g±0.5g  
Color: White/Natural  
Packing: 50pcs/bag, 1000pcs/ctn  
Ctn. Size(mm):450\*360\*310  
CBM/Ctn:0.0502m<sup>3</sup>  
Fit 80mm diameter cups  
Usually for hot drinking



**GO-CR901**

Size: 95\*25mm  
Thickness: 0.6mm  
N.W.:5g±0.5g  
Color: White/Natural  
Packing: 50pcs/bag, 1000pcs/ctn  
Ctn. Size(mm):400\*305\*490  
CBM/Ctn: 0.0598m<sup>3</sup>  
Fit 90mm diameter cups  
Usually for hot drinking

# CUP LID



## GO-CR806

Size: 84\*12mm  
Thickness: 0.6mm  
N.W.: 3.5g±0.5g  
Color: White/Natural  
Packing: 50pcs/bag, 1000pcs/ctn  
Ctn. Size(mm):450\*360\*240  
CBM/Ctn: 0.0389m<sup>3</sup>  
Fit 80mm diameter cups  
Usually for cold drinking

## GO-CR906

Size: 94.5\*12mm  
Thickness: 0.6mm  
N.W.:4.5g±0.5g  
Color: White/Natural  
Packing: 50pcs/bag, 1000pcs/ctn  
Ctn. Size(mm):400\*240\*490  
CBM/Ctn: 0.047m<sup>3</sup>  
Fit 90mm diameter cups  
Usually for cold drinking



## GO-CR80

Size: 85\*34mm  
Thickness: 0.6mm  
N.W.: 4g±0.5g  
Color: White/Natural  
Packing: 50pcs/bag, 1000pcs/ctn  
Ctn. Size(mm):405\*380\*360  
CBM/Ctn: 0.0554m<sup>3</sup>  
Fit 80mm diameter cups  
Usually for cold drinking

## GO-CR90

Size: 95\*38.2mm  
Thickness: 0.6mm  
N.W.:5g±0.5g  
Color: White/Natural  
Packing: 50pcs/bag, 1000pcs/ctn  
Ctn. Size(mm):500\*400\*275  
CBM/Ctn: 0.0608m<sup>3</sup>  
Fit 90mm diameter cups  
Usually for cold drinking

# PAPER CUP

## 12oz Single Wall Paper Cup

Size(cm): (TOP)9\*(Btm)5.9\*(High)11.2

Packing: 50pcs/bag, 1000pcs/ctn

Ctn. Size(mm): 460\*370\*370

CBM/Ctn: 0.063m<sup>3</sup>

Fit for our 90 cup lids

## 12oz Single Wall Paper Cup

Size(cm): (TOP)9\*(Btm)5.9\*(High)11.2

Packing: 50pcs/bag, 1000pcs/ctn

Ctn. Size(mm): 460\*370\*370

CBM/Ctn: 0.063m<sup>3</sup>

Fit for our 90 cup lids

## 8oz Single Wall Paper Cup

Size(cm): (TOP)8\*(Btm)5.04\*(High)9.5

Packing: 50pcs/bag, 1000pcs/ctn

Ctn. Size(mm): 410\*330\*360

CBM/Ctn: 0.0487m<sup>3</sup>

Fit for our 80 cup lids



## 8oz Ripple Wall

Size(cm): (TOP)8\*(Btm)5.04\*(High)9.5

Packing: 50pcs/bag, 1000pcs/ctn

Ctn. Size(mm): 410\*330\*420

CBM/Ctn: 0.0568m<sup>3</sup>

Fit for our 80 cup lids

## 8oz Double Wall

Size(cm): (TOP)8\*(Btm)5.04\*(High)9.5

Packing: 50pcs/bag, 1000pcs/ctn

Ctn. Size(mm): 410\*330\*360

CBM/Ctn: 0.0487m<sup>3</sup>

Fit for our 80 cup lids

## 8oz Double Wall

Size(cm): (TOP)8\*(Btm)5.04\*(High)9.5

Packing: 50pcs/bag, 1000pcs/ctn

Ctn. Size(mm): 410\*330\*360

CBM/Ctn: 0.0487m<sup>3</sup>

Fit for our 80 cup lids

## 12oz Single Wall

Size(cm): (TOP)9\*(Btm)5.9\*(High)11.2

Packing: 50pcs/bag, 1000pcs/ctn

Ctn. Size(mm): 460\*370\*370

CBM/Ctn: 0.063m<sup>3</sup>

Fit for our 90 cup lids

## 16oz Single Wall

Size(cm): (TOP)9\*(Btm)5.9\*(High)13.5

Packing: 50pcs/bag, 1000pcs/ctn

Ctn. Size(mm): 460\*370\*400

CBM/Ctn: 0.068m<sup>3</sup>

Fit for our 90 cup lids

## 20oz Single Wall

Size(cm): (TOP)9\*(Btm)5.9\*(High)16

Packing: 50pcs/bag, 1000pcs/ctn

Ctn. Size(mm): 460\*370\*430

CBM/Ctn: 0.0732m<sup>3</sup>

Fit for our 90 cup lids



# CUP HOLDER



4 Cup Holder Tray

**GO-CRT4-1**

Size: 225\*225\*50mm  
 N.W.:41g±3g  
 Color: Brown  
 Material : Corrugated Pulp  
 Packing: 75pcs/bag, 300pcs/ctn  
 Ctn. Size(mm): 460\*350\*465  
 CBM/Ctn: 0.0748m<sup>3</sup>  
 Capacity cups 8/ 10/ 12/ 14/ 16/ 20/ 24 oz



Tearable 4 Cup Holder Tray

**GO-CRT4-2**

Size: 215\*215\*47.3mm  
 N.W.: 37g±3g  
 Color: Brown  
 Material : Corrugated Pulp  
 Packing: 100pcs/bag, 400pcs/ctn  
 Ctn. Size(mm): 480\*380\*420  
 CBM/Ctn: 0.0766m<sup>3</sup>  
 Capacity cups 8/ 10/ 12/ 14/ 16/ 20/ 24 oz



2 Cup Holder Tray

**GO-CRT2-1**

Size: 225\*115\*50mm  
 N.W.: 21g±3g  
 Color: Brown  
 Material : Corrugated Pulp  
 Packing: 100pcs/bag,600pcs/ctn  
 Ctn. Size(mm): 475\*375\*465  
 CBM/Ctn: 0.0828m<sup>3</sup>  
 Capacity cups 8/ 10/ 12/ 14/ 16/ 20/ 24 oz

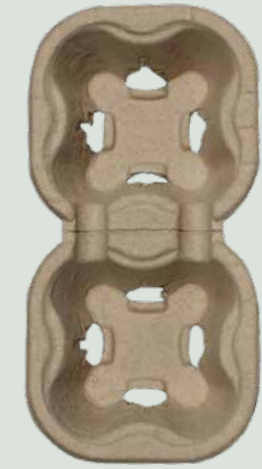

Tearable 2 Cup Holder Tray

**GO-CRT2-2**

Size: 218\*110\*47mm  
 N.W.: 21g±3g  
 Color: Brown  
 Material : Corrugated Pulp  
 Packing: 100pcs/bag,600pcs/ctn  
 Ctn. Size(mm):535\*450\*350  
 CBM/Ctn: 0.0842m<sup>3</sup>  
 Capacity cups 8/ 10/ 12/ 14/ 16/ 20/ 24 oz

# CUTLERY

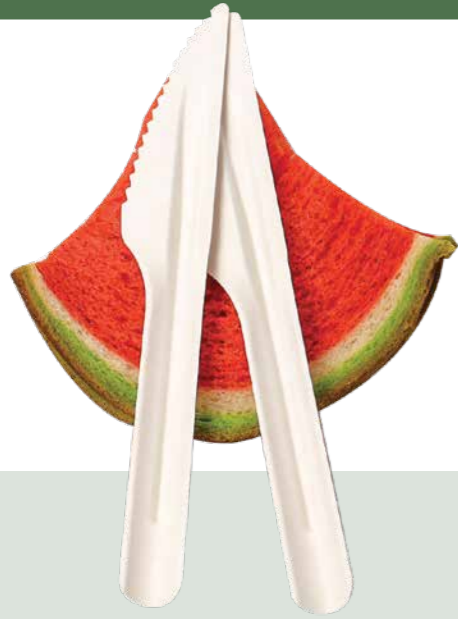

Knife

**GO-BK01**

Size: 162mm

Item Weight: 2.8g±1g

Color: White/Natural

Packing: 50pcs/bag, 5000pcs/ctn

Ctn. Size(mm):540\*440\*300

CBM/Ctn: 0.0713m<sup>3</sup>



Fork

**GO-BF01**

Size: 162mm

Item Weight: 2.8g±1g

Color: White/Natural

Packing: 50pcs/bag, 5000pcs/ctn

Ctn. Size(mm):540\*440\*300

CBM/Ctn: 0.0713m<sup>3</sup>

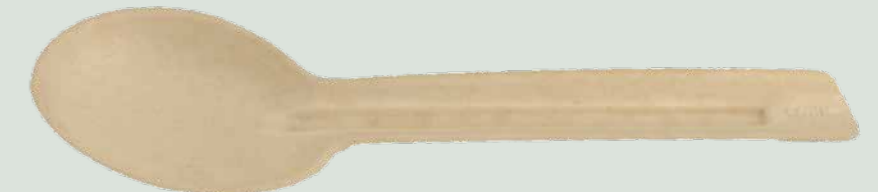

Spoon

**GO-BS01**

Size: 164mm

Item Weight: 3.8g±1g

Color: White/Natural

Packing: 50pcs/bag, 5000pcs/ctn

Ctn. Size(mm):540\*440\*300

CBM/Ctn: 0.0713m<sup>3</sup>

# TAKEOUT BOX



6 x 6 inch hinged burger box

**GO-FS06**

Size: 306\*149\*47.8mm  
Capacity 530ml  
N.W:20g±2g  
Packing: 125pcs/bag, 500pcs/ctn  
Ctn, Size(mm): 510\*318\*312  
CBM/Ctn: 0.0506m<sup>3</sup>



7 x 5 inch rectangle takeout box

**GO-FRT07**

Size: 273.5\*185.5\*44.8mm  
Capacity 655ml  
N.W:20g±2g  
Packing: 50pcs/bag, 500pcs/ctn  
Ctn. Size(mm): 580\*285\*405  
CBM/Ctn: 0.0669m<sup>3</sup>



9inch 3-compartment container lunch box

**GO-FS39**

Size: 463\*230\*49.6mm  
Capacity 1560ml  
N.W:42g±3g  
Packing: 100pcs/bag, 200pcs/ctn  
Ctn, Size(mm): 480\*360\*244  
CBM/Ctn: 0.0421m<sup>3</sup>

# TAKEOUT BOX



9inch container lunch box

**GO-FS09**

Size: 463\*230\*49.6mm  
Capacity 1560ml  
N.W:42g±3g  
Packing: 100pcs/bag, 200pcs/ctn  
Ctn, Size(mm): 480\*385\*250  
CBM/Ctn: 0.0462m<sup>3</sup>



8inch 3-compartment container lunch box

**GO-FS38**

Size: 432\*200\*44.3mm  
Capacity 1135ml  
N.W:37g±3g  
Packing: 100pcs/bag, 200pcs/ctn  
Ctn, Size(mm): 452\*434\*216  
CBM/Ctn: 0.0424m<sup>3</sup>



8inch container lunch box

**GO-FS08**

Size: 432\*200\*44.3mm  
Capacity 1135ml  
N.W:37g±3g  
Packing: 100pcs/bag, 200pcs/ctn  
Ctn, Size(mm): 452\*434\*216  
CBM/Ctn: 0.0424m<sup>3</sup>

# TAKEOUT BOX



9 x 6 inch rectangle takeout box

**GO-FRT09-01**

Size: 312.5\*230\*48.8mm  
Capacity 715ml  
N.W.:30g±3g  
Packing: 125pcs/bag, 250pcs/ctn  
Ctn, Size(mm): 495\*325\*250  
CBM/Ctn: 0.0402m<sup>3</sup>



5 compartment rectangle food tray

**GO-PRT5-1**

Size: 260\*210\*23mm  
N.W.: 21±2g  
Packing: 125pcs/bag, 500pcs/ctn  
Ctn. Size(mm): 430\*350\*275  
CBM/Ctn: 0.0414m<sup>3</sup>



8 x 6 inch rectangle market tray

Size: 212\*150\*24mm  
Capacity 300ml  
N.W.: 19g±2g  
Packing: 125pcs/bag, 500pcs/ctn  
Ctn. Size(mm): 320\*225\*480  
CBM/Ctn: 0.0345m<sup>3</sup>

# BOWL



16oz Bowl

**GO-BR16**

Size: 156\*55.3mm

Capacity 500ml

N.W.: 13g±1.5g

Packing: 100pcs/bag, 600pcs/ctn

Ctn. Size(mm): 495x325x355

CBM/Ctn: 0.0571m<sup>3</sup>



24oz Bowl

**GO-BR24**

Size: 165\*60.7mm

Capacity 750ml

N.W.: 16g±2g

Packing: 100pcs/bag, 600pcs/ctn

Ctn. Size(mm): 515x350x321

CBM/Ctn: 0.0578m<sup>3</sup>



32oz Bowl

**GO-BR32**

Size: 190\*73mm

Capacity 1000ml

N.W.: 20g±2g

Packing: 100pcs/bag, 600pcs/ctn

Ctn. Size(mm): 586x394x398

CBM/Ctn: 0.0919m<sup>3</sup>

# PLATE

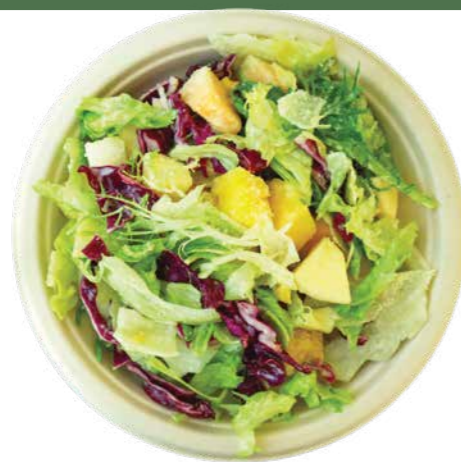
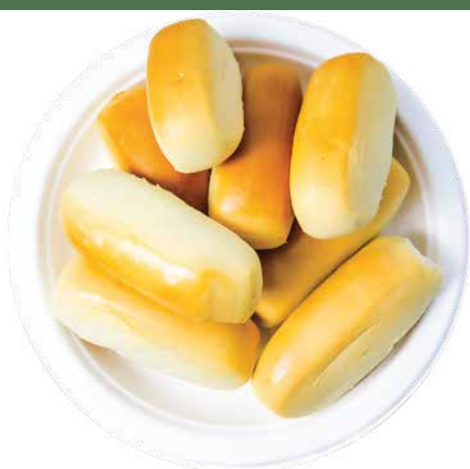

6 Inch Round Plate

**GO-PR06**

Size: 155\*16.3mm  
N.W:6.5g±1g  
Packing: 50pcs/bag, 1000pcs/ctn  
Ctn, Size(mm): 325\*265\*325  
CBM/Ctn: 0.0280m<sup>3</sup>



7 Inch Round Plate

**GO-PR07**

Size: 180\*18mm  
N.W:8g±1g  
Packing: 50pcs/bag, 1000pcs/ctn  
Ctn, Size(mm): 365\*285\*365  
CBM/Ctn: 0.0402m<sup>3</sup>



8.75 inch Round Plate

**GO-PR0875**

Size:220\*19.5mm  
N.W:14±2g  
Packing:125pcs/bag,500pcs/ctn  
Ctn.Size(mm):465\*315\*240  
CBM/Ctn: 0.0351m<sup>3</sup>

# PLATE

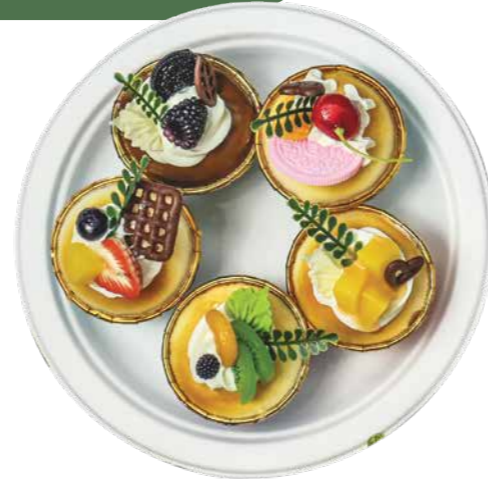
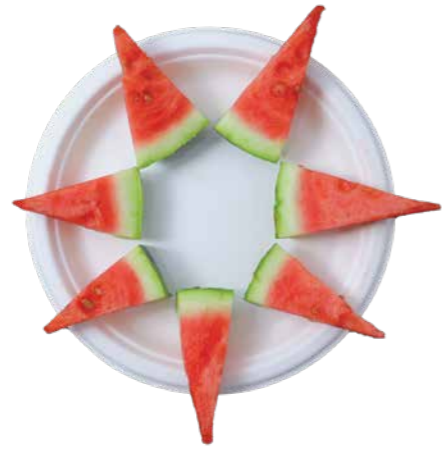

8.86 inch Round Plate

**GO-PR0886**

Size:225\*19.5mm

N.W:15±2g

Packing:125pcs/bag,500pcs/ctn

Ctn.Size(mm):465\*315\*240

CBM/Ctn: 0.0351m<sup>3</sup>



9 Inch Round Plate

**GO-PR09**

Size: 230\*20.5mm

N.W.: 15g±2g

Packing: 50pcs/bag, 500pcs/ctn

Ctn. Size(mm): 480\*390\*255

CBM/Ctn: 0.0477m<sup>3</sup>



10 inch Round Plate

**GO-PR10**

Size:260\*20.6mm

N.W:20±2g

Packing:125pcs/bag,500pcs/ctn

Ctn.Size(mm):535\*325\*270

CBM/Ctn: 0.0469m<sup>3</sup>

# PLATE



8.86 inch  
3-compartment Plate

**GO-PR3886**

Size:225\*19.5mm

N.W:15±2g

Packing:125pcs/bag,500pcs/ctn

Ctn.Size(mm):465\*345\*240

CBM/Ctn: 0.0385m<sup>3</sup>



10 inch  
3-compartment Plate

**GO-PR310**

Size:260\*25.5mm

N.W:20±2g

Packing:125pcs/bag,500pcs/ctn

Ctn.Size(mm):535\*345\*270

CBM/Ctn: 0.0498m<sup>3</sup>



8 inch Ellipse Plate

**GO-PE08**

Size:264\*200\*19.4mm

N.W:17±2g

Packing:50pcs/bag,500pcs/ctn

Ctn.Size(mm):540\*345\*215

CBM/Ctn: 0.0400m<sup>3</sup>



10 inch Ellipse Plate

**GO-PE10**

Size:319\*256\*24mm

N.W:30±2g

Packing:50pcs/bag,500pcs/ctn

Ctn.Size(mm):530\*320\*335

CBM/Ctn: 0.0568m<sup>3</sup>

# PLATE

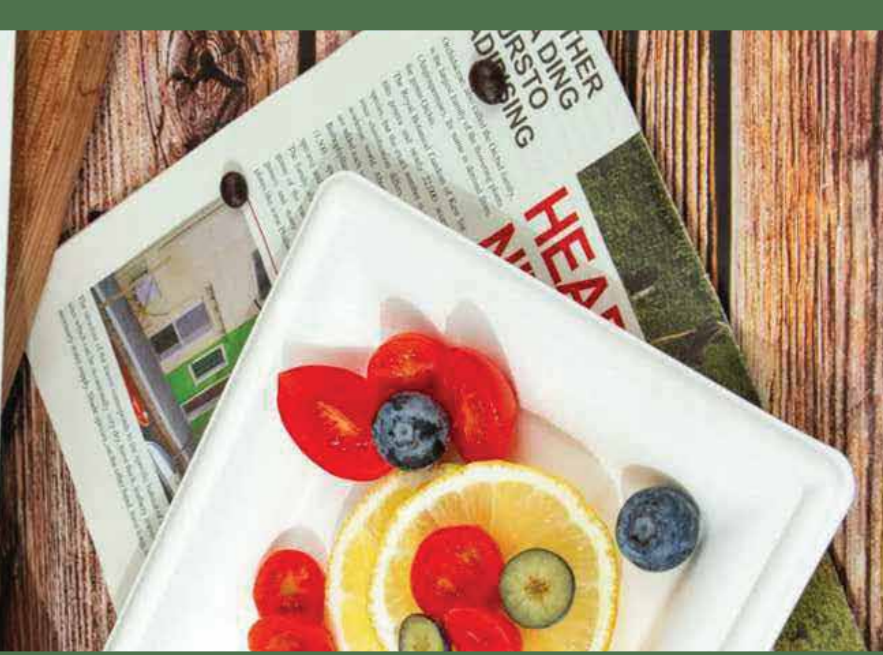

6 inch Square Plate

**GO-PS06**

Size:160\*160\*15mm  
N.W:13±2g  
Packing:50pcs/bag,500pcs/ctn  
Ctn.Size(mm):340\*280\*170  
CBM/Ctn: 0.0162m<sup>3</sup>



8 inch Square Plate

**GOPS08**

Size:200 \* 200 \* 15  
N.W:17±2g  
Packing:50pcs/bag,500pcs/ctn  
Ctn.Size(mm):560\*210\*210  
CBM/Ctn: 0.0247m<sup>3</sup>



10 inch Square Plate

**GO-PS10**

Size:260\*260\*15mm  
N.W:30±2g  
Packing:50pcs/bag,500pcs/ctn  
Ctn.Size(mm):570\*270\*270  
CBM/Ctn: 0.0415m<sup>3</sup>

# NEW PRODUCTS - SQUARE BOX



Customization



Customization



# OUR MATERIAL



Natural Color Bamboo Pulp



Bleached Bamboo Pulp

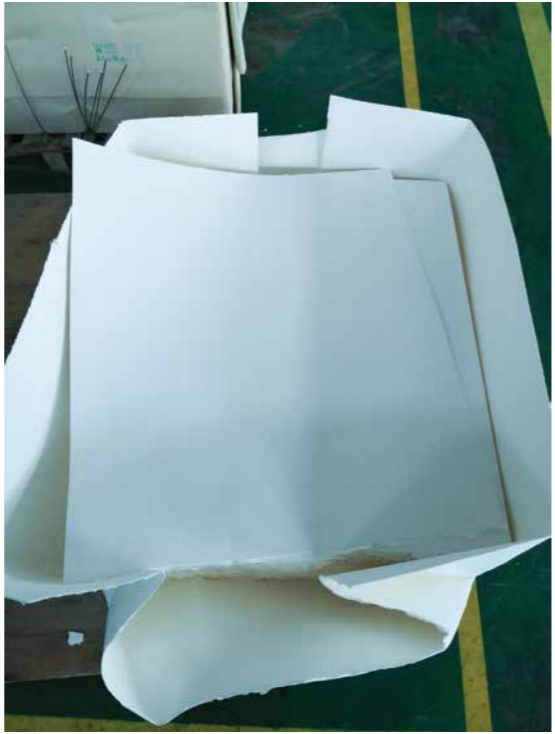

Natural Color Bagasse Pulp



Bleached Bagasse Pulp



For food safety and hygiene, Green Olive has implemented a rigorous quality control system from incoming material. Our materials are then purified, mixed in large vats, and extracted into molds to become cup lids, plates, cups, cutlery and bowls. The products are then dried and packaged for you to purchase and enjoy!

- Natural Plant Fibers
- Safe to Use & Compostable
- Eco-friendly
- Remarkably Durable
- 0% Plastic
- 100% Biodegradable

# COMMERCIAL PACKAGING

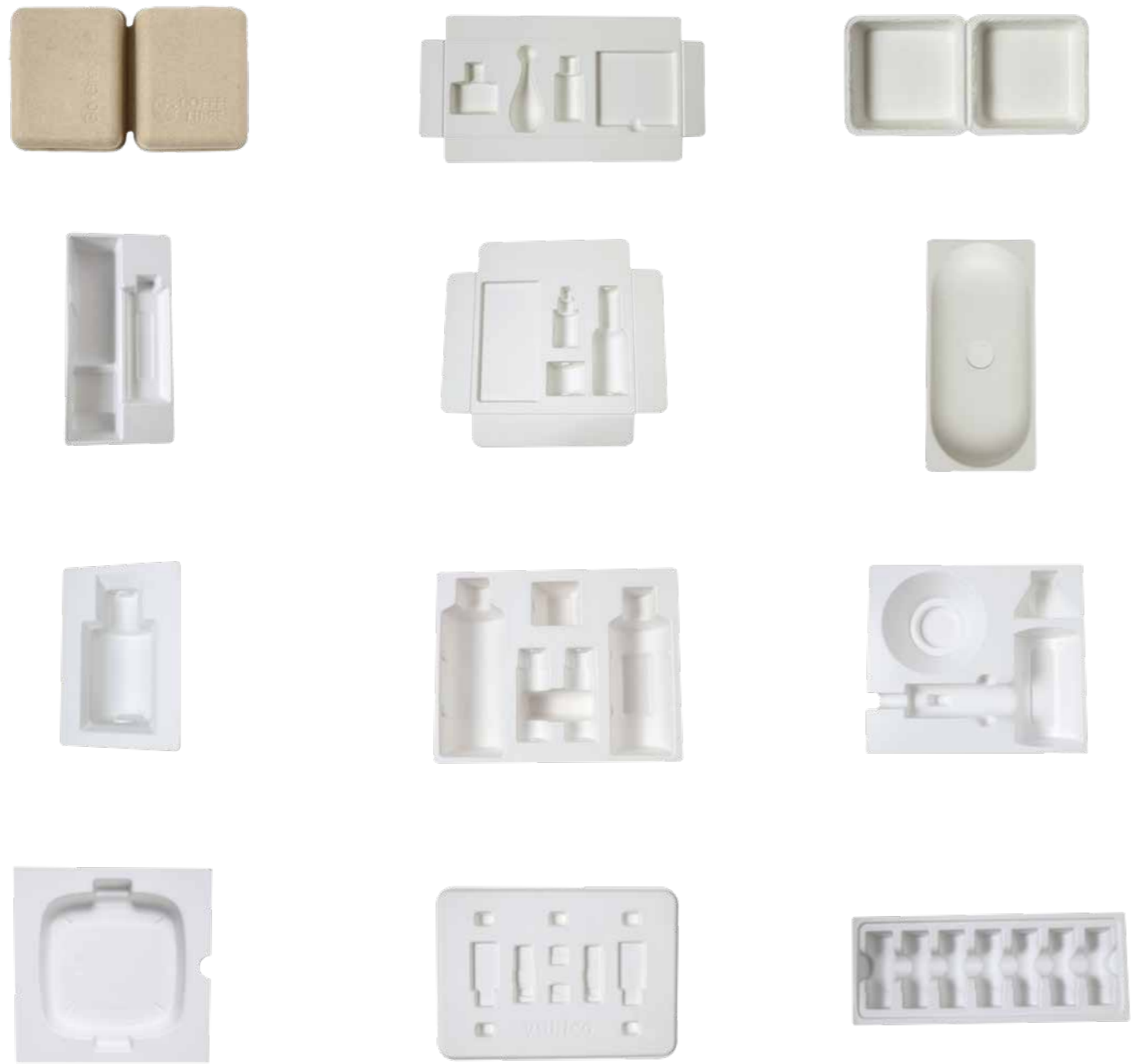

## flowchart

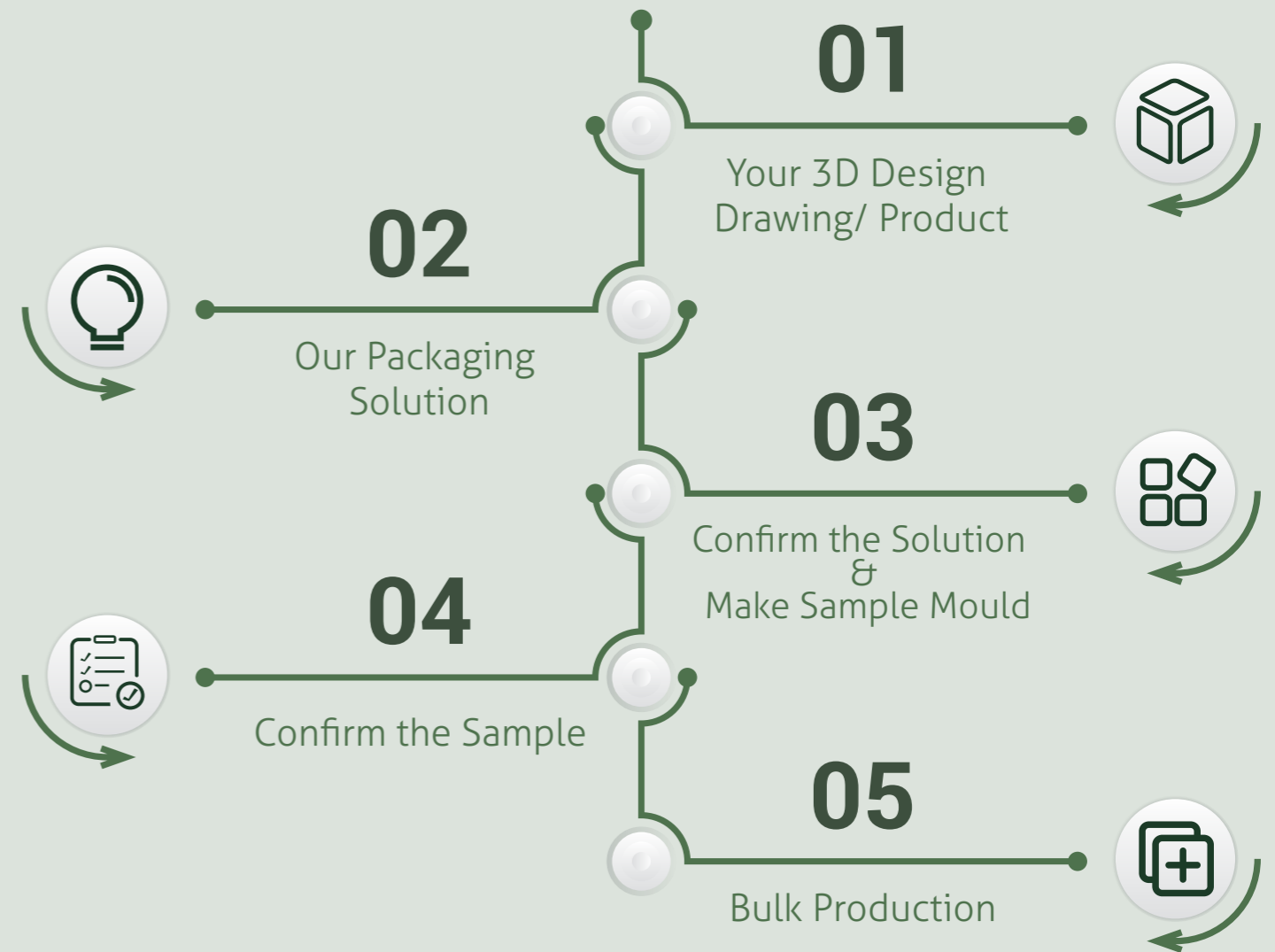

To provide you with one-stop service and professional support.



# OEM&ODM



- We research and develop new uses of molded pulp.
- We design workable and manufacturable packaging solutions based on different purposes and product features.
- We provide one-stop service from designing, mould developing, sample making to bulk manufacturing.
- We also assist in sourcing supporting packaging and relevant products from our cooperating partners.

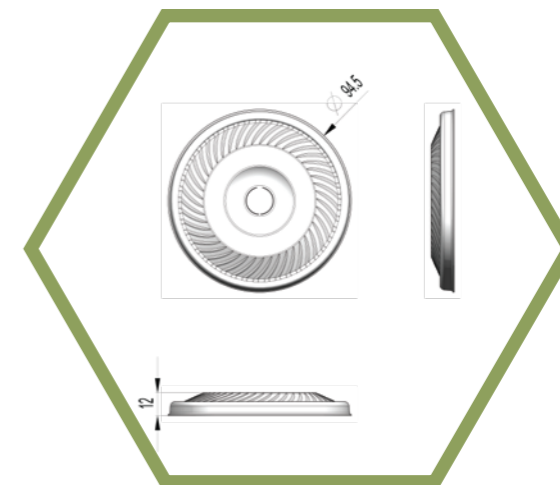
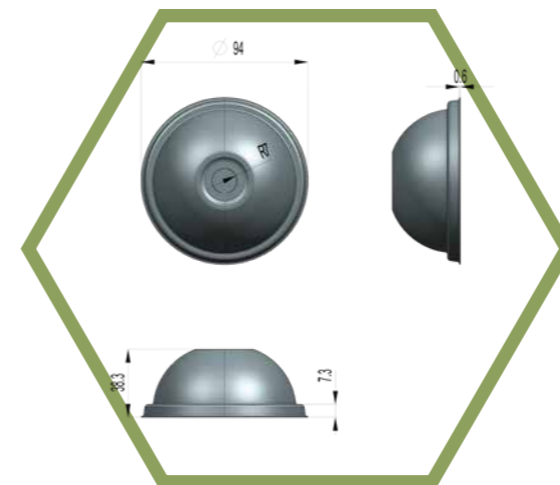
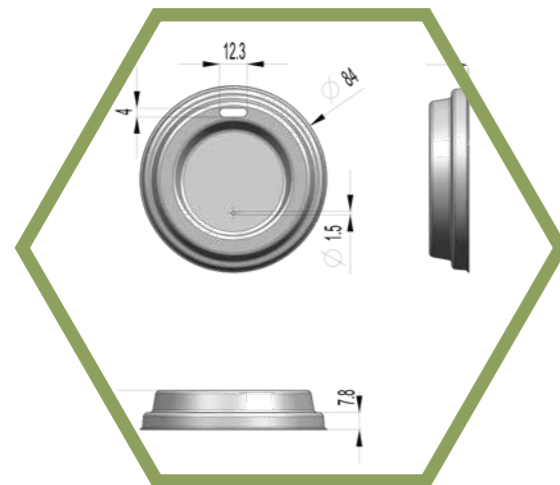
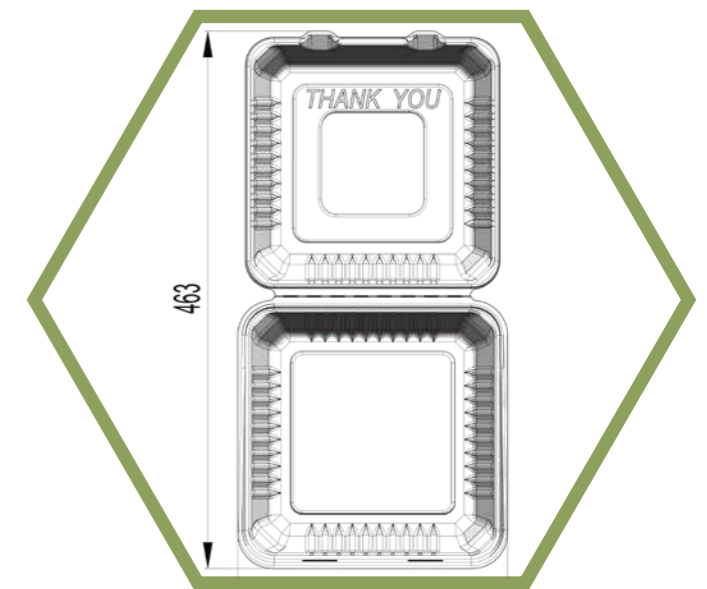
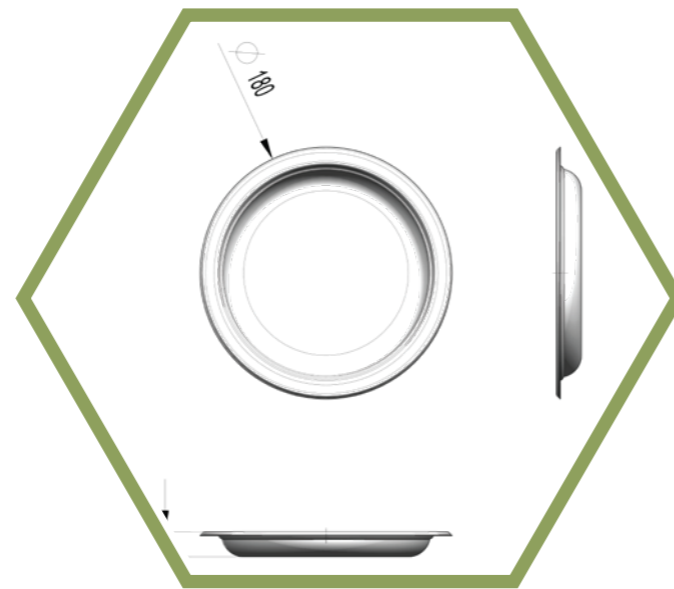
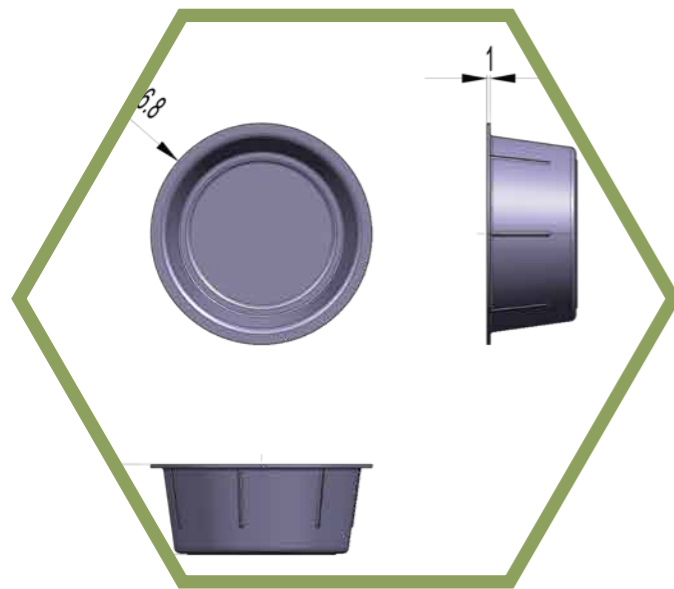

# MARKETS



AMERICA  
EUROPE  
AFRICA  
ASIA  
MIDDLE EAST

# GREEN OLIVE AROUND THE WORLD



## **Longyan Green Olive Co., Ltd. / 龙岩市青橄榄环保科技有限公司**

Head office: Room 906.Bldg.B.Business Center, Xinluo District, Longyan, Fujian 364000,China  
Factory Add: No. 2, Jindong 2nd Road, Fengcheng Street, Yongding South Industrial Park,  
Yongding District, Longyan, Fujian 364000,China

## **Dongguan Green Olive Co., Ltd./ 青橄榄环保科技（东莞）有限公司**

Office Add: Room 2815, Wanda Center, Dongcheng District, Dongguan,Guangdong,523000, China  
Tel: +86 0769-8630 7386  
Whatsapp: +86 181 5946 0878  
Email: Marketing@greenolives.com.cn

[www.ecogreenolive.com](http://www.ecogreenolive.com)



Official website