



**WELCOME TO**  
**Sunbright Precision Hardware Co., Ltd.**  
**新辉精密五金(惠州)有限公司**  
**Shenzhen Sunbright Technology Co., Ltd.**  
**深圳市尚佰利科技有限公司**



# PRECISION METAL MACHINING & FABRICATION

## 精密五金件加工及制造

**Product Customization**  
**Expert Since 1988**  
**ONE Stop Hardware Solution**

Precise Machining - Metal Fabrication Services - moulding



[Get instant quote](#)



# Company Profile 公司简介



Shenzhen Sunbright Technology Co.,Ltd.is a high-tech enterprise which integrates R&D, production and sales of high-end products and precision components.We provide customers with one-stop high-quality solutions from raw materials to process engineering and manufacturing.The factory area is approximately 50,000 square meters,total investment is about 60 million US dollars, with more than 1,000 sets of various advanced production machines and 20 sets of high-precision testing/inspection equipment.

深圳市尚佰利科技有限公司是一家集高端产品和精密零部件的研发、生产、销售为一体的高新技术企业。我们为客户提供从原材料到工艺工程和制造的一站式优质解决方案。厂区面积约50000平方米，总投资约6000万美元，拥有各类先进生产机器1000多台套，高精度检测/检测设备20台套。

# Company Profile 公司简介



We mainly offer CNC Precision Machining service, Metal Parts Fabrication service, Plastic Injection Molds, Top Ornaments and Beauty Care Tools etc. Products are widely used in communications, precision instruments, medical equipment, high-speed trains, auto, aviation and other industries. Sunbright has accumulated a large number of high-tech employees, 3 of them have more than 20 years industry experience and 20 of them have more than 10 years, which greatly reduces customer's communication costs and project development and manufacturing cycles.

我们主要提供CNC精密加工服务、金属零件制造服务、注塑模具、顶饰和美容护理工具等。产品广泛应用于通讯、精密仪器、医疗器械、高铁、汽车、航空等行业。Sunbright积累了大量的高科技员工，其中3人具有20年以上的行业经验，20人具有10年以上的经验，大大降低了客户的沟通成本和项目开发制造周期。

# Company Profile 公司简介

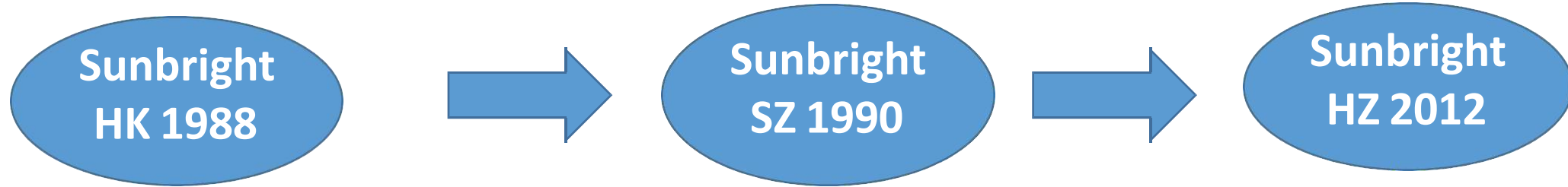

- Founded at Hongkong in 1988. 于 1988 年在香港成立。
- Established own factory at Buji Town, Shenzhen in 1990. 于1990年在深圳布吉镇建立了自己的工厂。
- Moved to Taimei Town, Boluo County, Huizhou City in 2012. 于2012年搬迁至惠州市博罗县台美镇。
- Implemented an ERP system in 2018. 于 2018 年引入了 ERP 系统。
- Passed NADCAP- NDT (magnetic particle inspection) certified in 2019. 于 2019 年通过了 NADCAP-NDT（磁粉检测）认证。
- Started implementing lean manufacturing system in 2020. Sunbrihgt 于 2020 年开始推行精益生产。

# CNC Machining Parts CNC加工零件

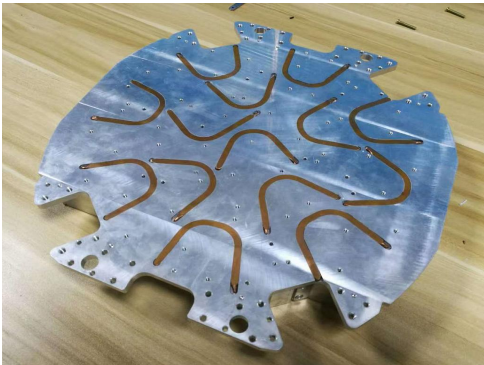
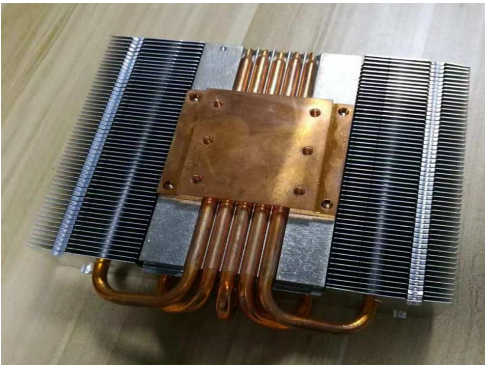
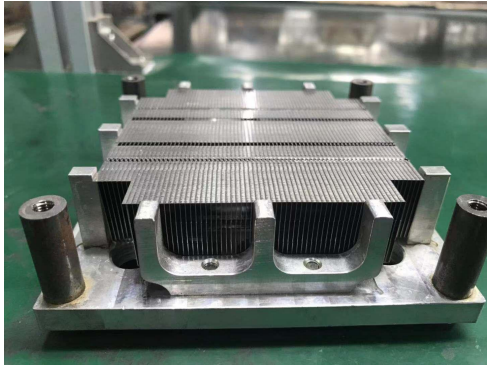
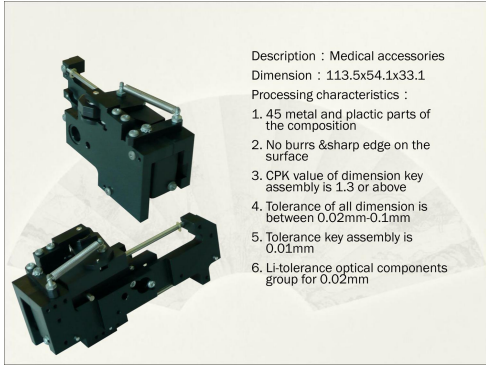
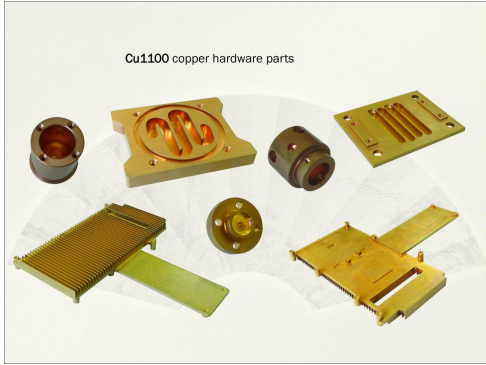

# Hardware Mold Manufacturing Parts 五金模具制造零件

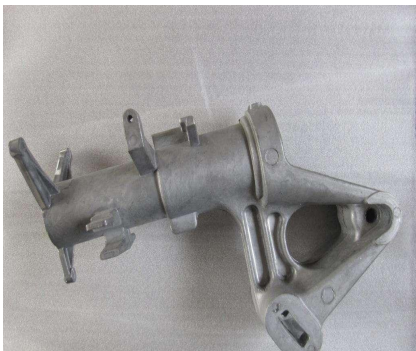
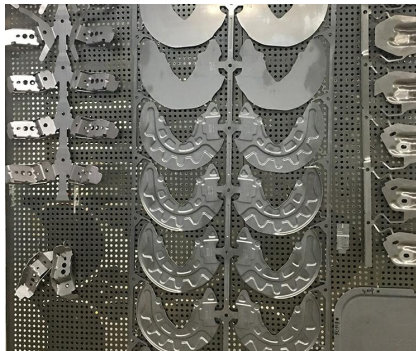

# Injection Parts 注塑件

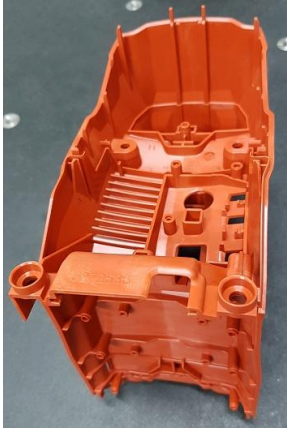
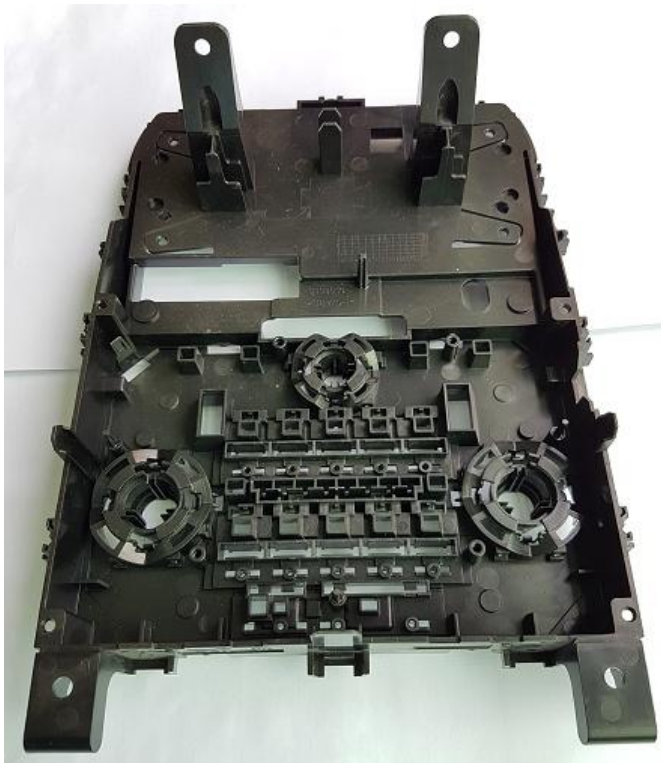
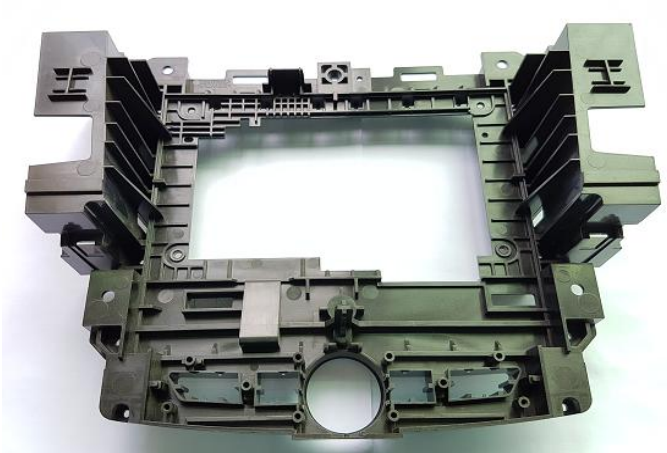

# Product Application 主要产品:



1. Civil aviation seat metal parts, civil aircraft kitchen spare parts, tray table, and so on (50%) 民用飞机座椅金属零配件, 民用飞机厨房零配件、餐台零配件;
2. Medical equipment accessories 医疗器械配件;
3. Automatic welding machine parts 自动焊机配件;
4. Control valve accessories 控制阀配件;

Most products sold to Europe and the United States market  
大部分产品销往欧美市场

## Key Customers 主要客户：

- MINDRAY, LEPU, PHILIPS: cooperate for 5 years each 分别合作5年
- ZODIAC/SAFRAN: cooperate for 15 years 合作15年
- BE AEROSPACE: cooperate for 15 years 合作15年
- SEAL-SEAT: cooperate for 32 years 合作32年
- LINCOLN: cooperate for 18 years 合作18年
- INVACARE: cooperate for 16 years 合作16年
- WESTERN: cooperate for 16 years 合作16年



# Operations 操作



From machining to fabrication to finishing, our advanced operations allow us to create specialized metal and plastic components at a great value with some of the fastest turnaround times in the industry. 从加工到制造到表面处理，我们的先进操作使我们能够以业界最快的周转时间创造出极具价值的专业金属和塑料部件。

## Fabrication 制造

- ✓ CNC Milling 铣削
- ✓ CNC Turning 车削
- ✓ Drilling 钻孔
- ✓ Tapping 攻牙
- ✓ Waterjet Cutting 水刀切
- ✓ Saw Cutting 切割
- ✓ Stamping 冲压
- ✓ Punching 冲孔
- ✓ Forming 成型
- ✓ Deep drawing 拉深
- ✓ Tube Bending 管弯曲
- ✓ MIG & TIG Welding 氩弧焊
- ✓ Spot Welding 点焊
- ✓ Robotic Welding 机器人焊接
- ✓ Brazing 铜焊

## Finishing 表面处理

- ✓ Deburring 去毛刺
- ✓ Grinding 碾磨
- ✓ Polishing 抛光
- ✓ Powder coating 喷粉
- ✓ Bead Blasting 喷砂
- ✓ Tumbling 滚磨
- ✓ Degreasing 除油
- ✓ Brite Dip (Brass) 酸洗
- ✓ Chemical conversion (Aluminum) 钝化（铝）
- ✓ Passivation 钝化(不锈钢)
- ✓ Pad Printing 产品印字

# Materials 原材料

Sunbright sources only the best quality raw materials that are certified and fully traceable from beginning to end of the supply chain. 新辉能提供最优质的原材料，包括从供应链开始到结束的认证和可追溯性。

## Material Sources 材料资源

- ✓ Bar stock 棒料
- ✓ Tubing 管料
- ✓ Sheet 片料
- ✓ Plate 板料
- ✓ Extrusions 型材
- ✓ Castings 铸造件
- ✓ Forgings 锻造件
- ✓ Molded parts 压铸件
- ✓ and more 等等

We provide materials that meet ASTM, AMS, and JIS standards and others upon request.



Steel 铁



Stainless Steel 不锈钢



Aluminum 铝



Forging 锻造件



Brass & Bronze 黄铜

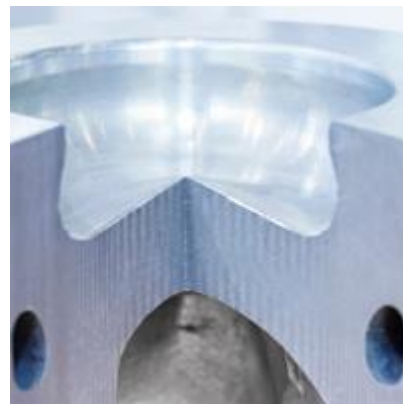

Castings 铸造件



Zinc 锌合金



Plastic 塑胶

# Equipment 主要设备



Quality machining and manufacturing starts with state-of-the-art equipment operated by expertly trained and experienced employees that utilize a clearly defined quality control system. 优质加工和制造始于先进的设备，由经过专业培训和经验丰富的员工操作，按照明确的质量控制体系来控制。

Our major production and measurement equipment includes :

- 150sets of CNC milling machines with rotary index from USA, Japan, Taiwan and Korea  
150台加工中心及分度头
- 34 sets of CNC turning lathe 34台车床
- 20 sets of forging machines 20台锻造机器
- 30 sets of die casting machines 30台压铸机器
- 1 sets of large stroke waterjet cutting machines 1台水刀机
- 1 set of Robotic welder 1台机械手烧焊机
- 20 sets stamping and deep drawing machines 20台冲床
- 1 sets Zeiss CMM 1台蔡司三次元
- 1 set Micro-Vu optical measuring machine 1台光学三测元
- 1 set contour measuring machine 1台轮廓仪
- 1 set spectrometer 1台光谱仪
- 1 set magnetic particle inspection machine 1台磁粉探伤机

# 150 TOTAL CNC MILLING MACHINES & ROTARY TABLES

## 150台CNC加工中心和分度头

EQUIPMENT MODEL 设备型号	QTY	FEATURES 特点
Fanuc Robodrill α14i Series	6	14-Tools/500mm x 400mm (X-YTravel)
Fanuc Robodrill α21i Series	3	21-Tools/500mm x 400mm (X-YTravel)
Fanuc Robodrill α14i L-Series	2	14-Tools/700mm x 400mm (X-Y Travel)/Long Table
Brother TC-S2A	1	14-Tools/500mm x 400mm (X-YTravel)
Tsudakoma Rotary Table	13	5-Axis/CNC Control
VMC-1400	1	24-tools/1400mmx720mm(X-Y Travel)
Doosan CNM 560	30	24-tools/560mm x 410mm (X-Ytravel)
S7 Linear motor CNC milling machine	3	20-tools/700mmx500mm (X-Y travel)/30000 turns spindle revolution/super high accuracy/marble bed structure/high speed
FHR-320 rotary table	1	320mm dia. mounting plate / rotary & tilting

EQUIPMENT MODEL 设备型号	QTY	FEATURES 特点
Tan Shing MRNC320 4th Rotary Index	5	400mm Diameter Mounting Plate
YCM CV-102A	6	24-Tools/1020mm x 600mm (X-YTravel)
Maxsee MSV-650	3	24-Tools/650mm x 410mm (X-YTravel)
YCM-CV65A	60	20-Tools/Heavy Duty/560mm x 410mm (X-Y Travel)
Doosan Infracore DNM 500	6	30-Tools/Heavy Duty/1020mm x 540mm (X-Y Travel)
Arcade AR2024L	1	24-Tools/560mm x 410mm (X-YTravel)
Arcade AR-3120L	5	24-Tools/650mm x 410mm (X-YTravel)
Tan Shing TRNC210 2-Axis Rotary Index	3	210mm Diameter Mounting Plate/Rotary & Tilting
Tan Shing VRNC210 4th Rotary Index	1	210mm Diameter Mounting Plate

## 34 TOTAL CNC LATHES

## 34台CNC车床



EQUIPMENT MODEL 设备型号	QTY 数量	FEATURES 特点
Takamaz X-10	1	Turret Type/Standard Machine
Takamaz X-12	1	Turret Type/Standard Machine with Milling Function
Takamaz XY-12	2	Turret Type/5-Axis Controllable/Diameter 42mm Bar Capacity Milling Function & Back Spindle
Hitachi Seiki TS-15	2	Turret Type/Tail Stock/Diameter 46mm Bar Capacity/Tailstock
Mazak Quick Turn Nexus100	4	Turret Type/Tail Stock/Diameter 42mm Bar Capacity/Tailstock
Techno Wasino G-07	3	Gang Type/Very High Precision with Robot
Nomura NN-10T	1	Swiss-Turn Machine/Standard Machine/Diameter 1/2" Bar Capacity with Bar Feeder
Nomura NN-10SII	1	Swiss-Turn Machine/Milling Function/Diameter 1/2" Bar Capacity with Bar Feeder
Nomura NN-10C	1	Swiss-Turn Machine/Standard Machine/Diameter 10mm Bar Capacity with Bar Feeder/High Speed
Nomura U-III	2	Swiss-Turn Machine/Diameter 1" Bar Capacity/Milling Function with Bar Feeder
Nomura NN-16SB7	2	Swiss-Turn Machine/Milling Function/Diameter 16mm Bar Capacity with Bar Feeder 5-Axis Controllable/Sub-Spindle

EQUIPMENT MODEL 设备型号	QTY	FEATURES 特点
Citizen BL-25	1	Swiss-Turn Machine/Diameter 1" Bar Capacity/Milling Function with Bar Feeder & Back Spindle
Takamaz Attack BII	1	Swiss-Turn Machine/Turret Type/Diameter 20mm Bar Capacity with Bar Feeder
Citizen B-12	1	Swiss-Turn Machine/Standard Machine/Diameter 1/2" Bar Capacity with Bar Feeder
Citizen A-16	2	Swiss-Turn Machine/Standard Machine/Diameter 16mm Bar Capacity with Bar Feeder
Citizen B-20	1	Swiss-Turn Machine/Standard Machine/Diameter 20mm Bar Capacity with Bar Feeder
Haas TL-2 CNC Lathe	1	For Over 1 Meter Long Shaft Turning
Nomura NN-32YB	1	Swiss-Turn Machine/Milling Function/Diameter 32mm Bar Capacity with Bar Feeder 5-Axis Controllable/Sub-Spindle
Nomura 20UB3	1	Swiss-Turn Machine/Milling Function/Diameter 1" Bar Capacity with Bar Feeder 5-Axis Controllable/Sub-Spindle
Doosan Puma 215II	2	turret type/ tail stock/ dia. 65mm bar capacity/ tailstock /max turning dia. 460mm, length 500mm
Doosan Lynx 225M	2	turret type/ tail stock/ dia. 65mm bar capacity/ tailstock /max turning dia. 460mm, length 500mm/side drilling

## 20 TOTAL FORGING MACHINES

## 20台锻造设备

EQUIPMENT MODEL 设备型号	QTY	FEATURES 特点
Hatebur AMP 70/哈特贝尔 AMP70 热锻生产线	5	Fully automated horizontal hot forging line
Duplex EXY12500 Wedge Hot Die Press/二重EXY12500 楔式热模压力机	7	Suitable for multi-step forging
South Korea JAEWOO 4000 tons forging production line/ 韩国JAEWOO 4000吨锻压生产线	4	4000T Force 400mm Stroke 50 Strokes per Minute
South Korea JAEWOO 6300 tons forging production line/ 韩国JAEWOO 6300吨锻压生产线	4	460mm Stroke

## 20 TOTAL STAMPING MACHINES

## 20台冲床

EQUIPMENT MODEL 设备型号	QTY	FEATURES 特点
World 200 Ton Press/200吨	1	Open Type Single Point Precision
150/200 Hydraulic Press/150吨 & 200吨	1	Deep Drawing
Fly Wheel Press/20-40吨	8	20-40 Tons Capacity
Degao 25T Punch Press/25吨	1	Open Type Single Point Precision
Degao 45T Punch Press/45吨	3	Open Type Single Point Precision
Degao 60T Punch Press/60吨	5	Open Type Single Point Precision
Degao 125T Punch Press/125吨	2	Open Type Single Point Precision

## 30 TOTAL DIE CASTING MACHINES

## 30台压铸设备

EQUIPMENT MODEL 设备型号	QTY	FEATURES 特点
RDC160C/冷室压铸机	10	Die Locking Force 1600KN, Die Stroke 350MM
RDC300/冷室压铸机	5	Die Locking Force 3000KN, Die Stroke 460MM
RDH38F/热室压铸机	5	Die Locking Force 380KN, Die Stroke 200MM
RDH18N/热室压铸机	5	Die Locking Force 180KN, Die Stroke 150MM
RDH138F/热室压铸机	3	Die Locking Force 1380KN, Die Stroke 290MM
RDH200M/热室镁合金压铸机	2	Suitable for magnesium alloy die casting

# MISC. EQUIPMENT MISC 其他设备清单



EQUIPMENT MODEL 设备型号	QTY	FEATURES 特点
Cummins Generator/发电机	2	250 KVA & 380KVA
Bead-Blasting Machine/喷砂机	3	Bead-Blaster
Ultrasonic Degreasing Machine/超声波清洗机	3	Degreaser
KTC Super EDM Drill SD-1M/微型孔打孔机	1	Drill Very Small Hole (Orifice)/Diameter 0.08mm (0.0003")
Saw Cutting Machines/锯床	many	Saw Cutter
OD Grinding Machine/外圆磨机	1	OD Grinder
OTC Daihen Robotic Welder/烧焊机器人	1	CNC Control/OTC Daihen Robot/All V6 + DA-300P TIG Power SourceDM-350 MIGPower Source
Fu Hui Automatic Saw Cutting Machine/自动锯床	1	GX-375NC/Servo Motor Control/Up to 60mm Round Bar Stock/75mm Tubing
Vapor Degreaser/除油机	1	MUO-3006R/3 Tanks/Each 195mm x 275mm x 320
Production Line Conveyor Belt/自动生产 组装线	1	40 Feet

EQUIPMENT MODEL 设备型号	QTY	FEATURES 特点
Flow Waterjet PRO 4020BAbrasive Cutting System/水刀机	2	Capacity: 2000mm x 4000mm Plate Dimension, +/-0.1mm Accuracy/CNC Control
Gold San CNC Wire-Cut Machine/线切割机	5	Capacity: 400mm x 500mm x300mm
Tube Roll-Forming Machine/弯管机	1	From Sheet/2mm (Thick) x400mm (Length) x 600mm (OD)
Spot Welding Machine/点焊机	1	4.5mm + 4.5mm Gage SteelSheets
Brushing Machine/拉丝机	3	Brushing
Jucai & Kobelco Screw Type Compressor/压缩机	2	50 & 100 HP
Wangfang CNC Bender/数控折弯机	1	Fully Automatic for Very Complex Tube Bending
CNC Welding Indexing/数控烧焊机	1	Fully Automatic for Very Complex MIG & TIG Welding
Ultrasonic Degreasing Machine/超声波机	2	Degreaser
Precision TIG 375 welder /TIG 电焊机	2	TIG 375
Tumbling Machines/滚磨机	4	Ultrasonic Tumbling Machine (Media is Small Stainless Steel Pins) & 600L Capacity

# QUALITY CONTROL EQUIPMENT 质量控制设备



EQUIPMENT MODEL 设备型号	QTY	FEATURES 特点
Deltronic Optical Comparator/投影仪	1	4" x 8" X-Y Travel/Digital Readout with Micro-Processor
AD-2045 Magnaflux magnetic particle inspection machine	1	Non destructive testing machine
AFFRI Hardness Tester (Digital Display)/硬度计	1	Digital Display/Tests Hardness of Material
Mitutoyo Contour Measuring Machine/轮廓仪	1	100mm x 50mm X-Z Travel/Very High Precision/Automatic
Edmunds Bore Gage/内径气动测量仪	1	Pneumatic Type
Mitutoyo Tools & Accessories/其他精密测量设备: 高度尺, 卡尺, 千分尺, 针规, 环规等	many	Pitch Micrometer/Digital Height Gage/Micrometer/Caliper/Torque Wrench Pin Gage Set/Thread Gage Set
Magnetic flaw detector 磁力探伤检测仪	1	Surface and near surface magnetic particle inspection

EQUIPMENT MODEL 设备型号	QTY	FEATURES 特点
Micro-Vu Excel 652 HC Automatic Measuring Center (Optical)/光学三次元	1	CNC Control/High Speed/High Precision/X-Y-Z Travel/650mm x 650mm x 250mm SPC & Reverse Engineering Function/20-370X Magnification
Zeiss CMM Contura G2 10166 RDS/蔡司三次元	1	1000mm x 1600mm x 600mm (X-Y-Z Travel)/Scanning Function/CNC Control
Hand-Type Hardness Tester/硬度计	1	For Thin Tubing or Extrusion
Two dimensional high speed dimensional measuring instrument TM-3000 二维高速尺寸测量仪	1	Position correction, OUT name change, measurement mode selection

# QUALITY CERTIFICATIONS 质量认证

Sunbright HZ is AS9100 certified. 新辉通过AS9100 认证

## QUALITY SYSTEM 质量体系

- ✓ Experienced Quality Assurance Team  
经验丰富的质量保证团队
- ✓ Advanced Quality Control Equipment  
先进的质量控制设备

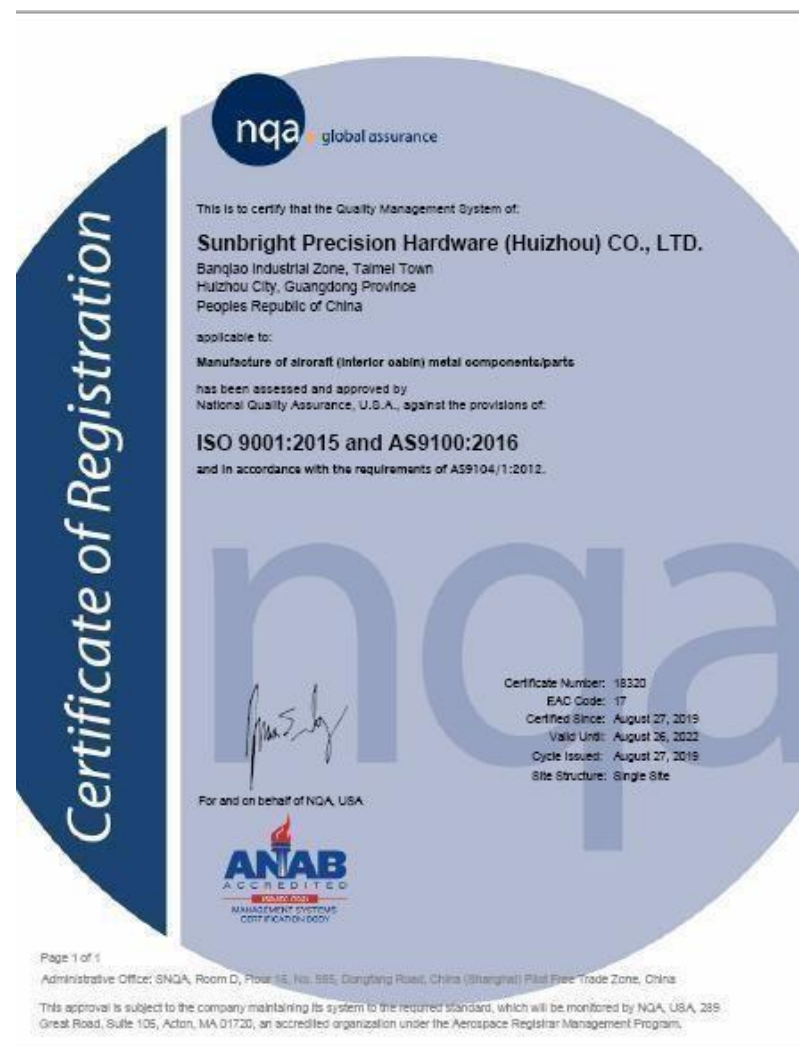



## QUALITY CERTIFICATIONS 质量认证

Sunbright HZ is NADCAP certified. 新辉通过 NADCAP 认证

### QUALITY SYSTEM 质量体系

- ✓ Additional high-quality inspection devices and gauges are used by our QA team in all manufacturing areas of the company. 我们的品质团队在公司的所有制造领域都使用其他高质量的检测设备和仪表。

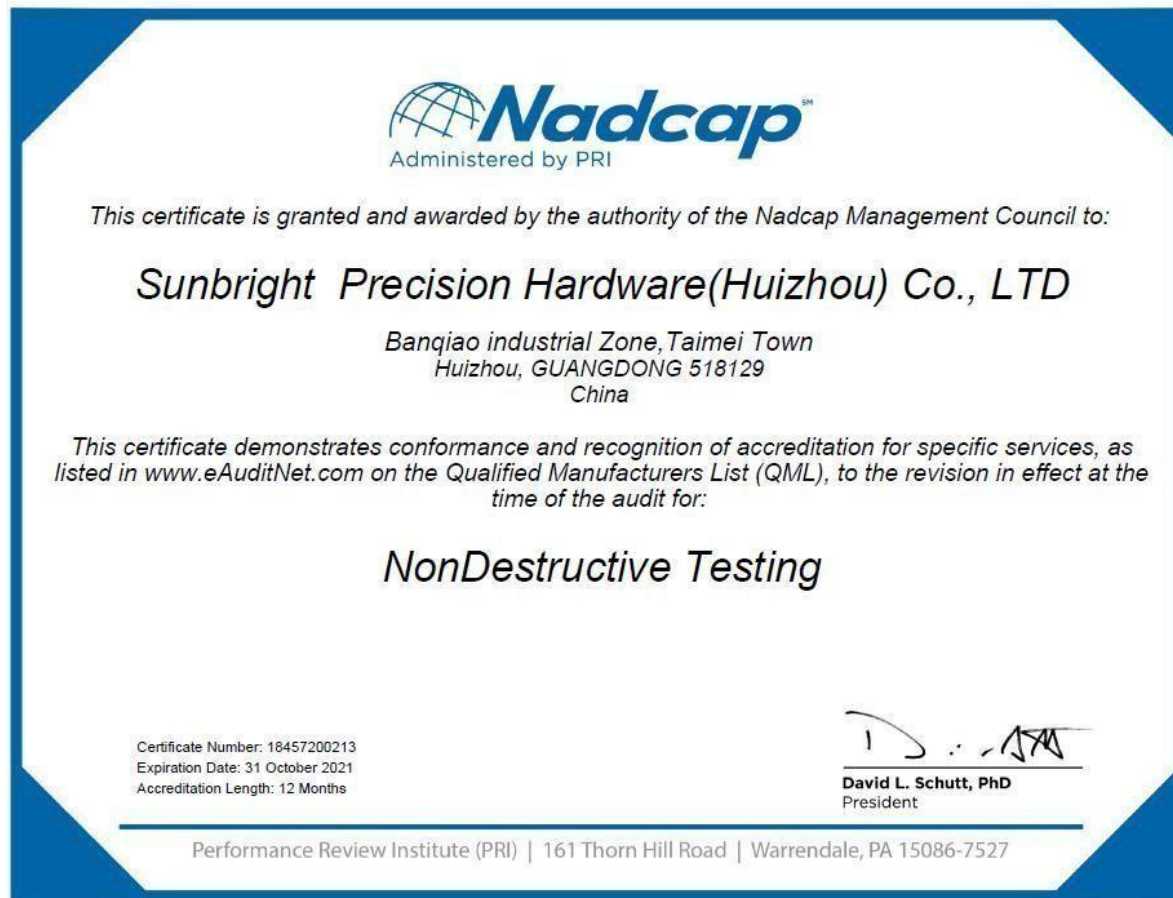



**Sunbright Precision Hardware (Huizhou) Co., Ltd.**  
**新辉精密五金(惠州)有限公司**

BAN QIAO INDUSTRIAL ZONE, TAIMEI TOWN, BO LUO COUNTY,  
HUIZHOU CITY,  
GUANG DONG PROVINCE, CHINA  
中国, 广东省, 惠州市, 博罗县, 泰美镇, 板桥工业区

TEL电话:+86-0752-6306900/6306911



**Shenzhen Sunbright Technology Co., Ltd.**  
**深圳市尚佰利科技有限公司**

B1227-1228, Yousong Science & Technology Building, 1st Road  
Donghuan, Longhua District, Shenzhen, China  
中国, 广东省, 深圳市, 龙华区, 东环一路, 油松科技大厦B1227-1228

TEL电话: 86-755-23739629